



UNIVERSAL INSTALLATION INSTRUCTIONS FOR CARPORTS

FRAME SIZES:

WIDTH: 10, 12', 14', 16, 18', 20', 24', AND 30'

ON CENTER FRAME SPACING: 4', 4 1/2', AND 5'

FRAME LENGTH: 4' ON CENTER 20'-2", 4 1/2' ON CENTER 18' AND 5' ON CENTER 20'

EAVE HEIGHTS: START AT 7' TO 12 1/2' .

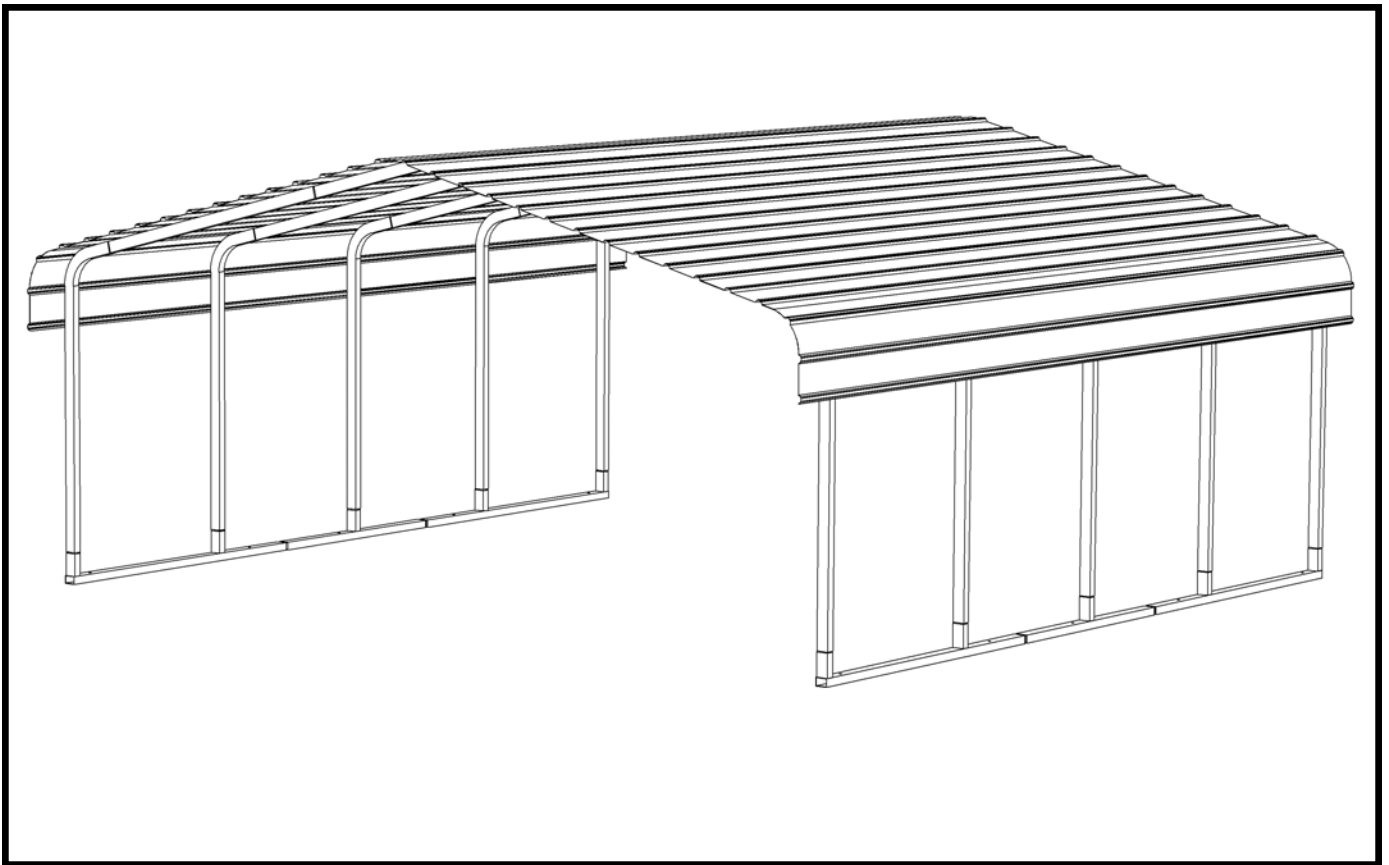

Our unique assembly process quickly transforms the individual pieces into a finished structure that will give you a lifetime of service. Great care has been taken to ensure complete satisfaction with your purchase. In the unlikely event that there are any missing or damaged parts, or if you simply need technical assistance, please call our Toll Free Hotline at 1-800-900-7222 and your questions will be addressed promptly. Thank you for choosing the VersaTube Building System.

SAFETY, HAZARD, AND MAINTENANCE INSTRUCTIONS

CAUTION:

Read the following safety warnings and all instructions in their entirety prior to installation. If you have questions or are missing any parts, contact Mid-South Metal Products, Inc. (DBA, VersaTube Building systems) customer service at 1-800-900-7222 before proceeding.

CAUTION:

VersaTube Building Systems designs and manufactures framing products to meet minimum load requirements in most areas. It is the buyer's sole responsibility to determine the specific building code requirements applicable in the city and/or county of the state in which this product is being erected, and to ensure the product is installed with sufficient materials and in such a manner as to comply with the codes.

WARNING:

Metal parts may get hot when exposed to high heat or direct sunlight. Avoid contact with skin and wear protective gloves and clothing to prevent the possibility of burns.

WARNING:

Standing or walking on the structure could cause damage to the sheet metal panels. If you must walk on the roof, step within 1' of a major frame member. The structure must be properly braced to support human weight. Collapse of the structure may cause serious injury do to weight of components.

WARNING:

Avoid installation on windy days as wind may create hazards during the installation process. Wind may blow material or cause partially installed components to collapse prior to being secured or fully installed. The weight of the components or structure may cause serious injury if it should collapse.

WARNING:

Metal conducts electricity and electrical shock hazards exist since the structure is made of metal. During installation or storage, keep the structure and all components away from electrical sources. Make sure that your selected location is away from power lines, underground cables, and any other source of electrical power. Serious injury or even death may occur if contact is made with electrical current.

WARNING:

In the event that your structure is fully enclosed, be sure to provide proper and adequate ventilation and egress and ingress. Hazardous, poisonous or noxious substances should not be stored in the structures absent proper ventilation. Follow all warnings and instructions of the manufacturer of any substance stored in your building. Also, proper ingress and egress should be provided to prevent persons or children from becoming trapped inside the structure.

WARNING:

If metal panels are selected to cover all or a portion of your structure, be careful of the sharp edges which may cause cuts or lacerations. Wear protective work gloves and suitable clothing for protection and always take care when handling metal parts.

NOTE:

The VersaTube Building System is an all domestically produced galvanized tubular steel framing system. Maintenance is required twice annually on particular areas of the framing system i.e. "weld seams" and "cut or raw ends". This maintenance is performed by applying any "Zinc coated" silver spray paint found at local mass merchant or paint store to these areas twice annually or every six (6) months.

NOTE:

All sheet metal cladding applied to the VersaTube frame are attached with self drilling screws with a rubber washer. These screws produce small shavings when drilling through the cladding. If the shavings are allowed to sit on the sheet metal for an extended period, rust spots will form and promote deterioration. Metal shavings must be brushed after installation of the sheet metal. Claims reported against rust spots will not be honored by VersaTube Building Systems.

ATTENTION:

IT IS IMPORTANT THAT YOU READ THE FOLLOWING NOTE BEFORE STARTING THE ASSEMBLY OF YOUR CARPORT

NOTE:

If during the installation process you have difficulty fitting frame components together, use an adjustable wrench to open the end of the receiving tube as shown below. Close wrench down around bent portion of tube and bend wall outward. It may also be helpful to hit the center of the swage at the end of the tube to create more of a lead.

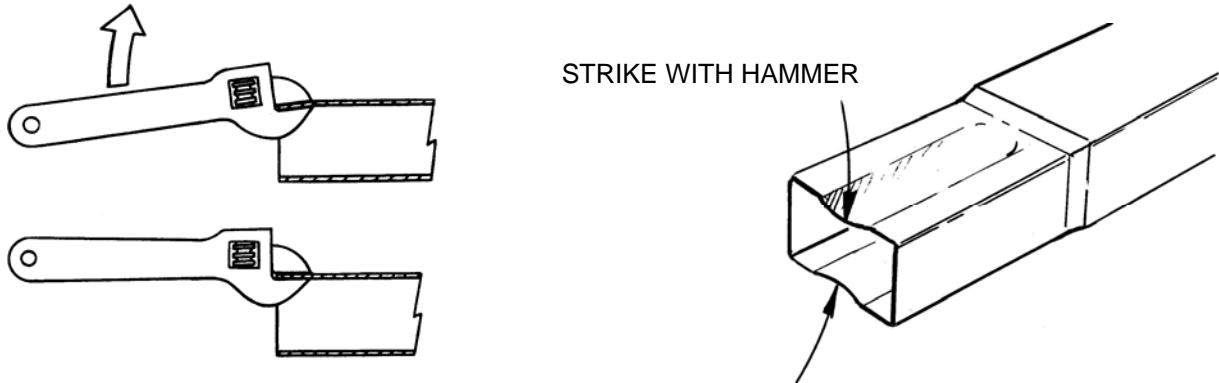

What you'll need

Torque Setting
Cordless (14 or 18 volt) Or Electric Screw Gun With 5/16" Socket Drive



Chalk Line and Mason Line or Nylon String



One must be able to comfortably reach the peak of the building 10' to 16' high depending on building width and height. An extension ladder can also be helpful when installing sheet metal.

2 Step Ladders



Safety Goggles Or glasses



Level



Shovel or Post Hole Digger



Work Gloves



Pencil/Marker And Felt Marker



Tape Measure

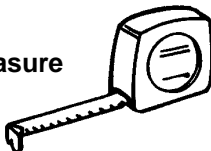

Hammer



Tin Snips



Items you may need

Adjustable wrench



Hammer Drill

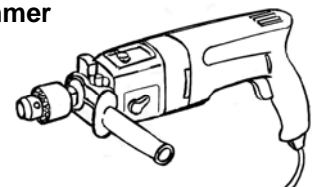

Masonry Drill Bit 1/2" x 8" Drill depth



Motor Cycle or Ratchet Straps



Wrench, 3/4" & 1/2"



Vise grip or other quick clamp

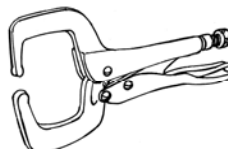

(May be required to pull frame plumb.)

BASIC CARPORT PARTS LIST

BASE RAILS

4' ON CENTER FRAMES:

8' STARTER BASE RAIL, 2" X 3" X 96 1/2" rail with 3 welded vertical pins. QTY. 2, part # 71-4783

8' BASE EXTENSION RAIL, 2" X 3" X 100 3/4" rail with 2 welded vertical pins, swaged one end. QTY. 2, part # 71-4782

4' BASE EXTENSION RAIL, 3" X 3" X 53" rail with 1 welded vertical pin. Swaged one end. QTY. 2, part #71-7020

4 1/2' ON CENTER FRAMES:

END BASE RAIL, 2" X 3" X 83 3/4" rail with 2 welded vertical pins, swaged one end. QTY. 4, part # 71-4802

CENTER BASE RAIL, 2" X 3" X 56" rail with 1 welded vertical pin in center. QTY. 2, part # 71-4801

5' ON CENTER FRAMES:

END BASE RAIL, 2" X 3" X 83 3/4" rail with 2 welded vertical pins, swaged one end. QTY. 4, part # 71-4500

CENTER BASE RAIL, 2" X 3" X 80" rail with one welded vertical pin in center. QTY. 2, part # 71-4000

NOTE: The length of the carport can be extended using 4', 4 1/2', 5' base extensions, one on each side of the carport. 4' # 71-7020, 4 1/2' # 71-7050, 5' # 71-7010.

SIDE POST, 2" X 3" tube with a bend at one end. QTY. 10 on 4 1/2' and 5' on center frames. QTY. 12 on 4' on center frames. Part # 71-5000 (7 1/2') or # 71-5007 (7') or # 71-5008 (8').

PEAK, 2" X 3" X 72" with one bend in the center. QTY. 5 on 4 1/2' and 5' on center frames. QTY. 6 on 4' on center frames. Part # 71-6000

HEIGHT EXTENSIONS (optional) Height extensions are 2" x 3" tubes with a swage at one end. They come in net height increments (the height from the end to the swage) of 1' to 5'. Part # HE-1, HE-2, HE-3, HE-4, HE-5.

RAFTERS,

10' wide carport, 2" x 3" tube swaged both ends. Part # 71-1500, QTY. 10 on 4 1/2' & 5' OC frame, 12 on 4' OC.

12' wide carport, 2" x 3" tube swaged both ends. Part # 71-2000, QTY. 10 on 4 1/2' & 5' OC frame, 12 on 4' OC.

14' wide carport, 2" x 3" tube swaged both ends. Part # 71-3000, QTY. 10 on 4 1/2' & 5' OC frame, 12 on 4' OC.

16' wide carport, 2" x 3" tube swaged both ends. Part # 71-3300, QTY. 10 on 4 1/2' & 5' OC frame, 12 on 4' OC.

18' wide carport, 2" x 3" tube swaged both ends. Part # 71-3500, QTY. 10 on 4 1/2' & 5' OC frame, 12 on 4' OC.

20' wide carport, 2" x 3" tube swaged both ends. Part # 71-8000, QTY. 10 on 4 1/2' & 5' OC frame, 12 on 4' OC.

24' wide carport, 2" x 3" tube swaged both ends. Part # 71-8300, QTY. 10 on 4 1/2' & 5' OC frame, 12 on 4' OC.

30' wide carport, 2" x 3" tube swaged both ends. Part # 71-8400, QTY. 10 on 4 1/2' & 5' OC frame, 12 on 4' OC.

VINYL TRIM, Length will change depending on the size of the carport. Part # 9901-VTW

BUTYL TAPE, Length will change depending on the size of the carport. Part # 71-9401

FRAME SCREWS, # 12 hex head, Self-Drilling screws. Come in 70 pack #71-9999 or 40 pack # 71-9999-A
SCREWS FOR ROOF METAL, #12 X 1" painted screws with rubber washers.

VERSATUBE ANCHORS, Anchors may or may not be supplied.

REBAR ANCHOR, used with concrete. #4 x 30" rebar with welded top plate. # ANC-24 Use 1 per post.

Concrete Wedge Anchors 1/2" x 7" are not supplied.

SHEET METAL PANELS, Sizes listed on page 15.

TRUSS BRACES: Truss braces may be required on your carport depending on width, wind load and snow load.

10', 12' and 14' wide carports do not require a truss brace. Two types of truss braces are available. Type 2 (collar tie with a vertical support) and type 3 (a collar tie with web angle braces and knee braces) See the part descriptions in that section.

SITE PREPARATION FOR CARPORTS

The Versatube carport frame is designed to be placed on a foundation that is level side to side and sloped about 1/8" per foot front to back or back to front. That foundation can be: **prepared ground** (leveled and re-compacted), a **concrete footing**, or a **concrete mono slab with built-in footing**. It is important that you create one of these conditions prior to your carport or building installation. We recommend that you check with your local building official prior to starting your project to find out what is acceptable for foundations and anchoring in your county. If you extend the carport site about 3 or 4 feet on all sides, it will make it easier to position ladders for sheet metal installation.

SLAB WITH FOOTING OR FOOTINGS ALONE

If you will be pouring a slab for your carport, the slab should be 4" thick and have a footing down both sides. The footing should be 12" x 12" with a 45° blend between the slab and the footing. The slab should have a front to back or back to front slope of about 1/8" per foot. One run of #5 rebar mid-depth is recommended in the footing. Check with your local building official for details and requirements in your county. Some counties require the footing to extend down 1' below the frost line. The concrete should be 2500 to 3000 PSI.

The outside dimensions of the slab should be at least 3" larger than your frame dimensions. Example: if you have a 20' x 20' frame, the slab should be at least 20'-3" x 20'-3". This will allow the center of your anchor bolts to be 3" from the edge of the slab.

FOOTINGS: Footings alone should be 12" wide and 12" deep and can be positioned so the base rails are centered in the footing if you will be using wedge anchor bolts to anchor the base rails. The outside dimension of the footing will be the carport width plus 9". The basic carport 5' On Center frame is 20' long. The 4 1/2' On Center frame is 18' long and the 4' On Center frame is 20'-2". Footings should be 3" longer than your frame. Footings should also slope 1/8" per foot front to back or back to front to allow water that might gather in horizontal ribs to flow over roof lap joints and off the roof.

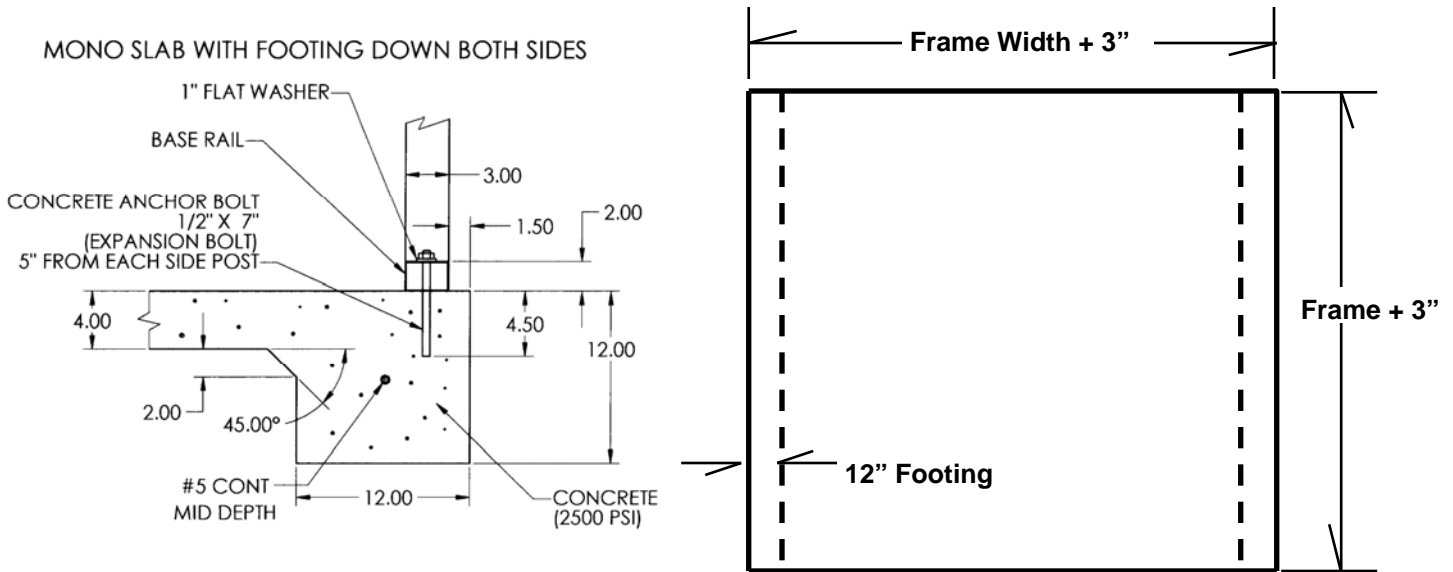

ASSEMBLING AND POSITIONING THE BASE RAILS:

Layout the base rails on your slab or footing or prepared ground. The base rails should be 10', 12', 14', 16', 18', 20', 24', or 30' apart (outside to outside) depending on the carport that you purchased. The length from the front to the back of the base rail assembly will be 1/2" longer than the frame length. (Example: If you have a 20' x 20' frame, the length of the base rail assembly will be 20'-1/2". The dimension from the front of the front vertical pin to the back of the back vertical pin will be 20'.) Note that the base rail layout for 5' and 4 1/2' On Center frame sections is the same. The layout for 4' On Center frame sections is different. On 4' On Center frames, the length of the basic base rail assembly will be 20'- 2 1/2" from the end of the front base rail to the end of the back base rail.

Join all the base rail components as shown. Check the overall length of the assembly, keep the swage joints even in length and fasten the swage joints with (2) #12 hex head, self drilling screws per joint on top of the base rail. Place the Left and Right base rail assemblies 10', 12', 14', 16', 18', 20', 24', or 30' apart (outside to outside) and take a measurement across the diagonals of the frame to check it for square. Adjust the frame until the measurements are equal.

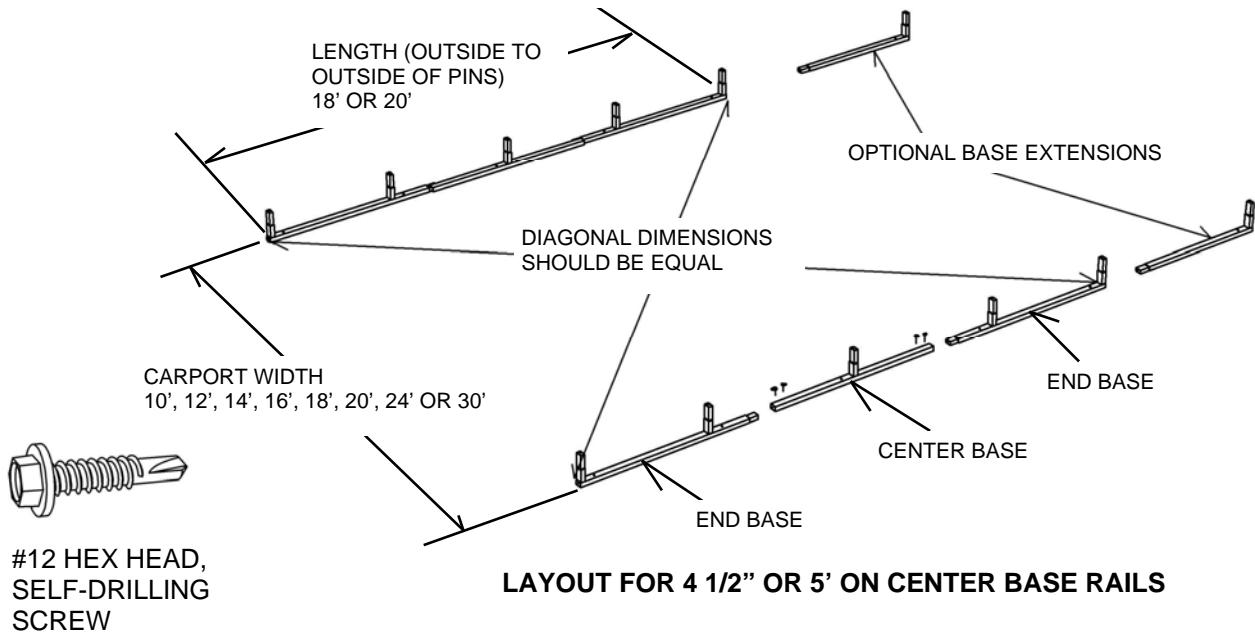

LAYOUT FOR 4' ON CENTER BASE RAILS

The base rail layout for 4' On Center frame sections has two 8' starter rails, two 8' base extension rails and two 4' base extension rails. If additional length is needed, you can add additional 4' or 8' base extensions.

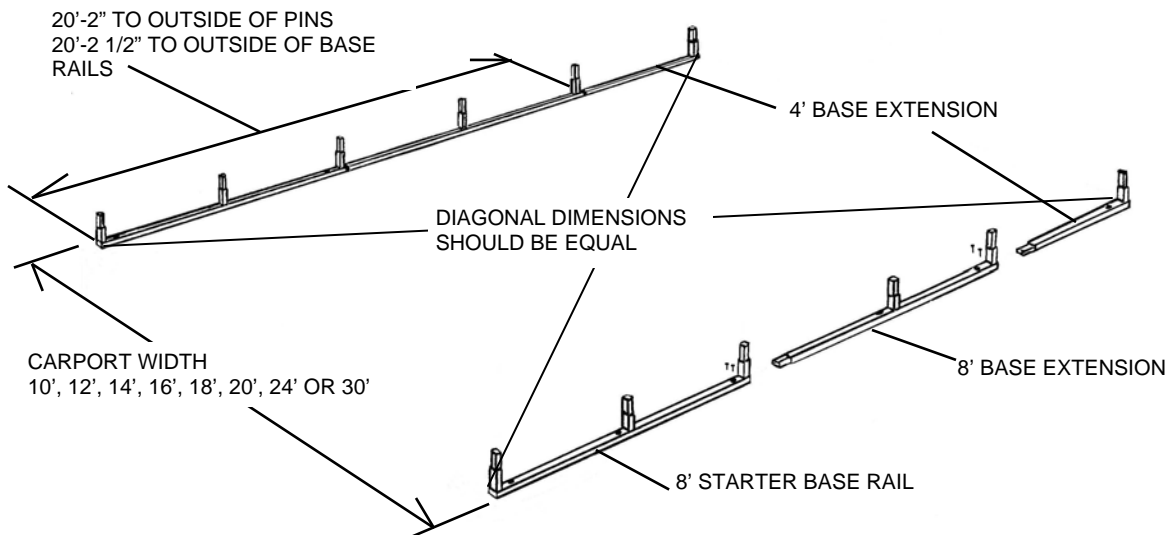

ANCHORING CARPORT BASE RAILS:

These instructions offer three anchoring methods: (1) To a concrete slab or concrete footings with concrete wedge anchor bolts. (2) To the ground with Versatube Ground Anchors. (3) To the ground with Versatube Rebar Anchors and concrete.

ANCHORING TO CONCRETE SLAB OR FOOTING WITH 1/2" X 7" WEDGE (EXPANSION) BOLTS

After you have completed all measurements and have the base rails in place and squared, screw the joints together with 2 screws per joint on the top surface of the base rail. This will assure that the rails remain straight and do not vibrate apart when you drill the anchor holes in the concrete.

To drill the anchor holes, you will need a hammer drill and a 1/2" x 8" or 12" concrete drill bit.

Hold the base rail in place with your foot, insert the drill bit through the anchor hole in the base rail and drill a hole 5" into the concrete. The base rail is 2" thick, so the total depth from the top of the base rail will be 7".

Place a flat washer onto the anchor bolt and screw on a hex nut until about 2 threads are exposed above the nut. Now, place the bolt in the hole and tap it down with a hammer until the nut and washer touch the top of the base rail. Use a 3/4" wrench to tighten the nut. Tighten the nut until it is snug. Do not crush the base rail tube.

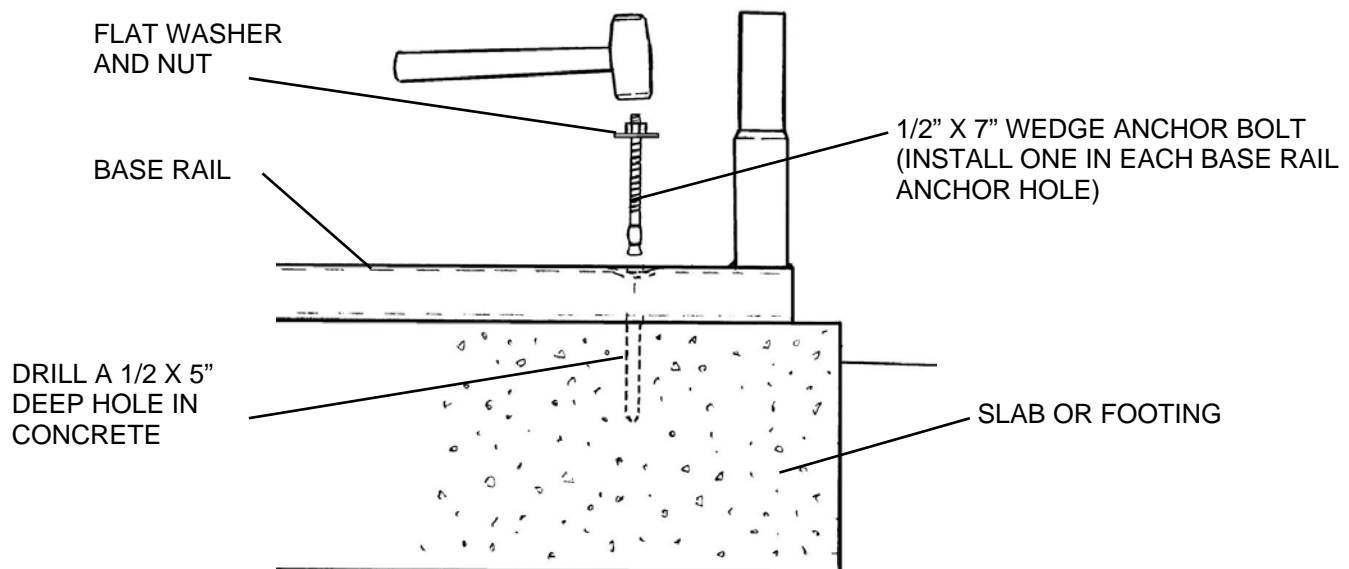

ANCHORING TO GROUND WITH CONCRETE PIERS

DIGGING HOLES FOR CONCRETE

Mark the locations of the rails and the anchor holes on the ground. Move the base rails to one side and dig holes at each anchor point for concrete. You may want to rent a gas-powered post hole digger with an 8" or 12" diameter auger for this job.

HOLE SIZE:

Counties with 70 or 80 mph Exposure C wind: Use a 12" diameter hole 14" deep or a 8" diameter hole 18" deep.

Counties with 90 mph Exposure C wind: Use a 12" diameter hole 18" deep or an 8" diameter hole 24" deep for 12' to 20' wide carports. For 24' and 30' wide carports, use a 12" diameter hole 21" deep or a 8" diameter hole 30" deep.

ANCHORING

Move the base rails back into position over the holes. Re-measure to make sure the rails are in the proper location (see layout on page 6).

Now drop or drive a Versatube 30" re-bar ground anchor with a flat washer and nut at the top into each anchor hole. A 24" rod could also be used. Mix up concrete and pour into holes up to ground level. You may want to rent a mixer for this job. Before the concrete sets, re-check all your dimensions to make sure the frame is square and has the proper width.

Let the concrete cure overnight before installing the Roof/Wall assemblies.

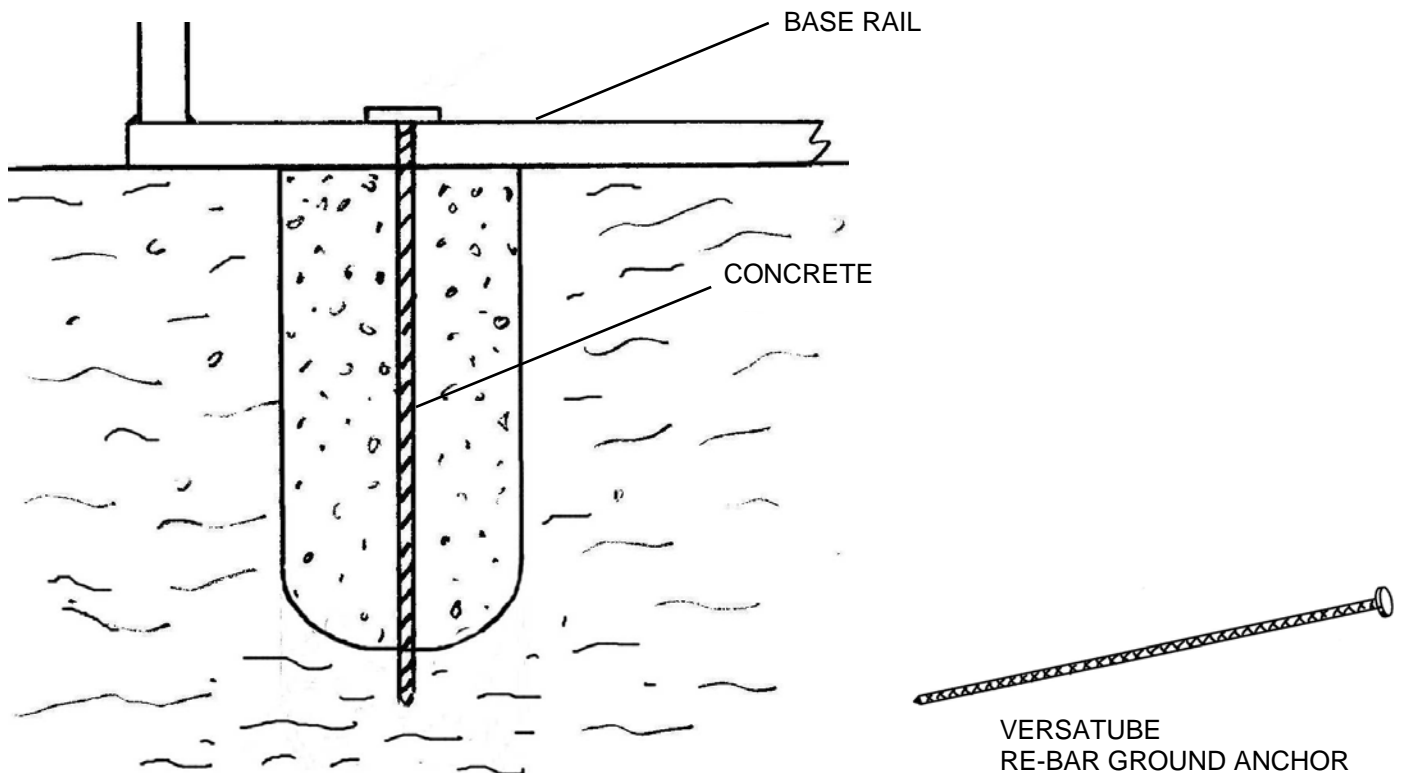

NOTE: If it is necessary to assemble and anchor the carport all in one work session, you can anchor the carport after it is complete. If you assemble the frame and install sheet metal before anchoring the base rails, it is important to have the site prepared and level. This will allow you to get the frame square and the sheet metal properly aligned with the frame.

ROOF/WALL FRAME ASSEMBLY

Before you start the assembly of the Roof/Wall sections, stack the Peak tubes, line up the ends and mark a line on the top of each peak 17 1/8" or 3 5/8" from one end. This will be the location of the edge of your first run of sheet metal panels on the roof of the carport. If your carport is 10', 12', 18', 24', or 30' wide place the mark at 17 1/8" from the end. If your carport is 14' or 20' wide, place the mark 3 5/8" from the end.

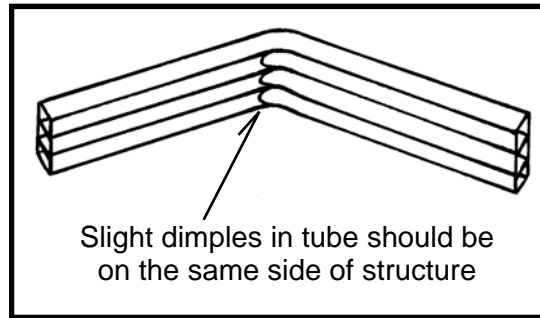
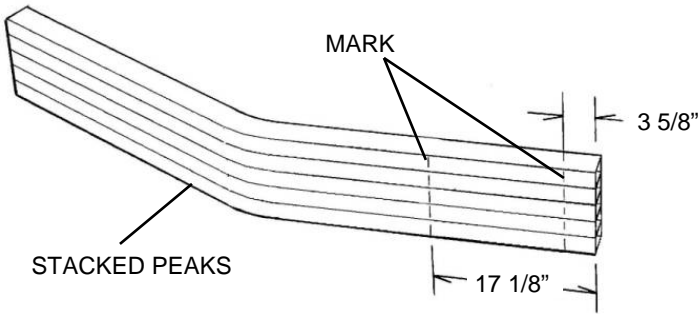

On the ground, assemble (1) peak, (2) rafters, (2) side posts, and (2) height extensions. (8', to 12 1/2' side height carports require height extensions.)

Before you fasten the joints with screws, take a measurement across the top and bottom of the assembly as shown. This outside measurement is the outside size of your carport. (10', 12', 14', 16', 18', 20', 24', or 30') Try to keep the joint spacing on both sides of the assembly equal. **It is very helpful to drive stakes into the ground at the width of the building and use them to set the dimension at the bottom of the assembly. You should set the bottom dimension before you adjust and set the top dimension.**

Now, fasten the joints with #12 hex head, self-drilling screws. Use 4 screws in the peak to rafter and side post to rafter joints and 2 screws in the height extension joints. See details below.

NOTE: You can use the first assembly as a template to assemble the remaining Roof/Wall Frames.

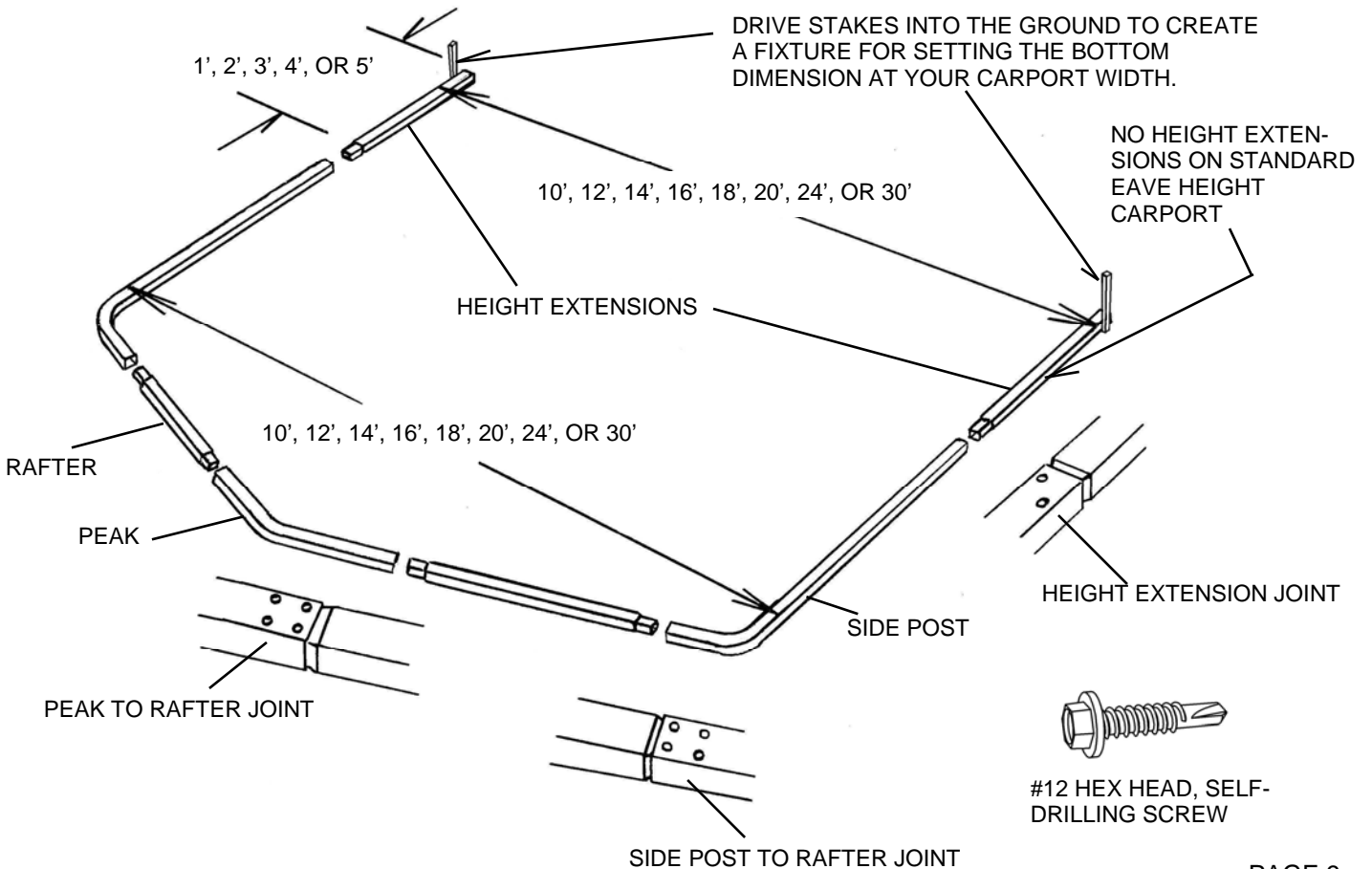

TRUSS BRACING:

TYPE (2) COLLAR TIE WITH VERTICAL, TYPE (3) COLLAR TIE WITH WEB BRACES

Your carport may or may not require a truss brace depending on carport width and the wind and snow load in your county. 10', 12' and 14' wide carports do not require truss braces. 16', 18', and 20' carports often do not require a brace. 24' and 30' wide carports require a brace. Check with your dealer if you have questions.

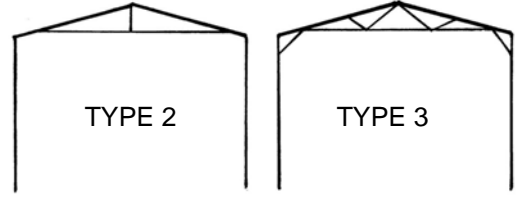

COLLAR TIE WITH VERTICAL BRACE

COLLAR TIE WITH WEB BRACING

NOTE: TRUSS BRACES ARE USED ON ALL INSIDE FRAME SECTIONS, NOT ON THE TWO END FRAME SECTIONS.

COLLAR TIE ASSEMBLY:

Collar Ties are made up of 3 parts: (1) Center Tie 2" x 2" x 111" long swaged (reduced) on both ends (part #74-1110) and (2) end ties. End Ties are 2" square tube. On 16' wide carports 26 1/2" (part #7400-2650) On 18' wide carports 38 1/2" (part #7400-3850), on 20' wide carports 50 1/2" long (part #7400-5050). On 24' wide carports 74 1/2" long (part #7400-7450). On 30' wide carports 111" long (part #7400-11100).

Assembly: Place an End Tie on both ends of the Center Tie and fasten each joint with (6) #12 hex head, self-drilling screws. Place screws on one side of the assembly as shown. Note: Make sure the assembly is straight when you install screws.

Install a left and right Collar Tie Bracket on both ends as shown. For structures 30'W or larger, Collar Tie Brackets will be provided for the front and back of each collar tie assembly.

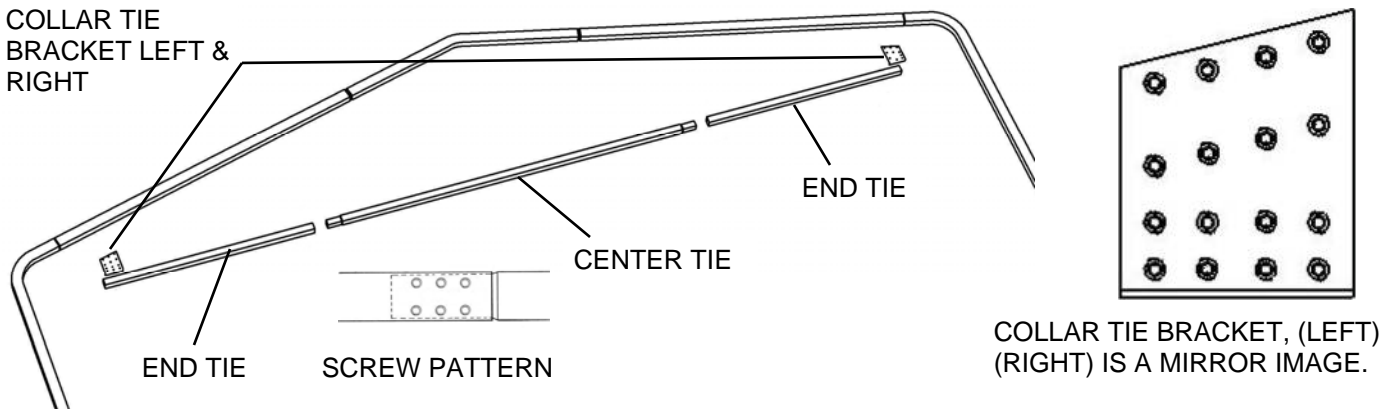

ASSEMBLY OF COLLAR TIE TO ROOF/WALL FRAME:

The collar tie must be centered in the frame. Take a measurement from the end of the side post to the collar tie bracket on both ends of the truss brace. Adjust the brace side to side until the measurements are equal. Fasten the collar tie brackets to the rafters with (8) self-drilling screws on each side of the assembly.

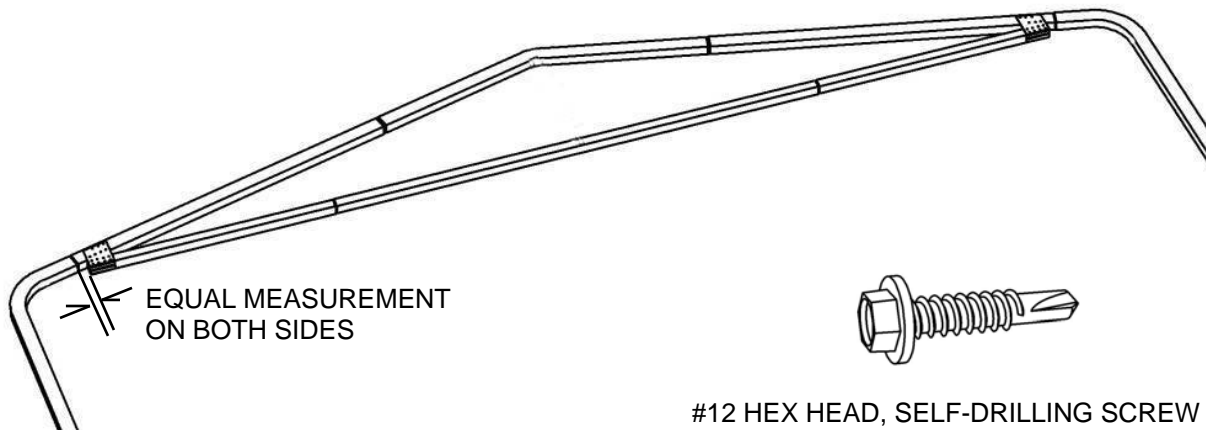

#12 HEX HEAD, SELF-DRILLING SCREW

INSTALLING VERTICAL BRACE FOR BRACE TYPE (2) TRUSS BRACE

The Center Vertical Brace is 1 1/2" square x 19 1/4" long on 16 wide carport, 22 1/4" on 18' wide, 25 1/4" long on 20' wide, 31 1/4" wide on 24' wide and 40 1/4" long on 30' wide. Fasten the brace to the Collar Tie and the Frame Peak with Single Purlin Brackets. Use two screws in the bracket tongue and one screw in each side flange as shown. Fasten the brackets to the vertical brace first. Place the assembly together and adjust the parts to fit before installing any screws. Make sure that the Collar Tie assembly is straight before you fasten the brace to the Collar Tie and Peak.

CENTER BRACE PART NUMBERS:

16W: PART # 7500-01925
 18W : PART #7500-02225
 20W: PART #7500-02525
 24W: PART #7500-03125
 30W: PART #7500-04025

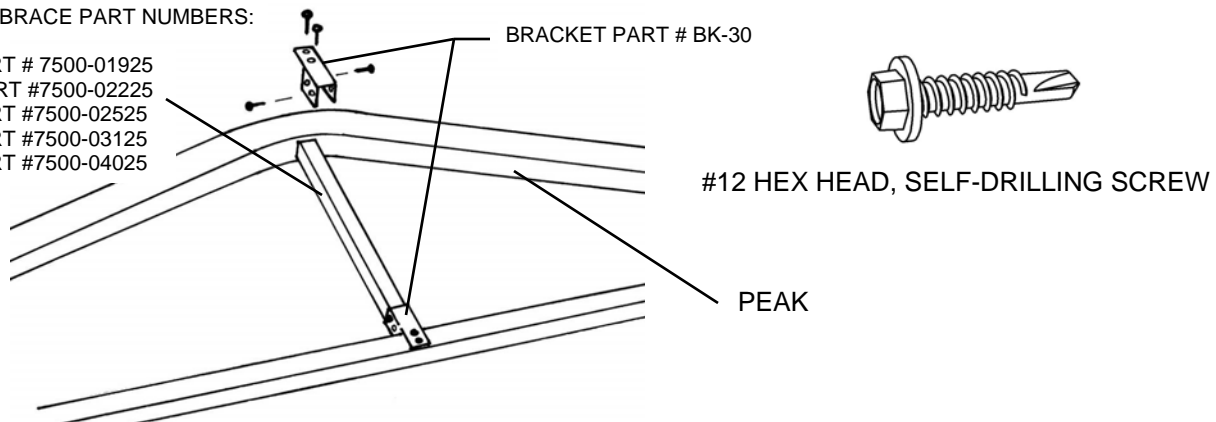

INSTALLING WEB BRACING FOR TYPE (3) TRUSS BRACE: WEB BRACING ON 20', 24' AND 30' ONLY.

STEP 1: INSTALLING THE PEAK WEB BRACKET.

Measure up from both ends of the peak to find the center and make a mark. Place a Web Bracket centered at your mark and pressed against the bottom of the peak. Fasten the Bracket to the peak with 3 self-drilling screws as shown in detail.

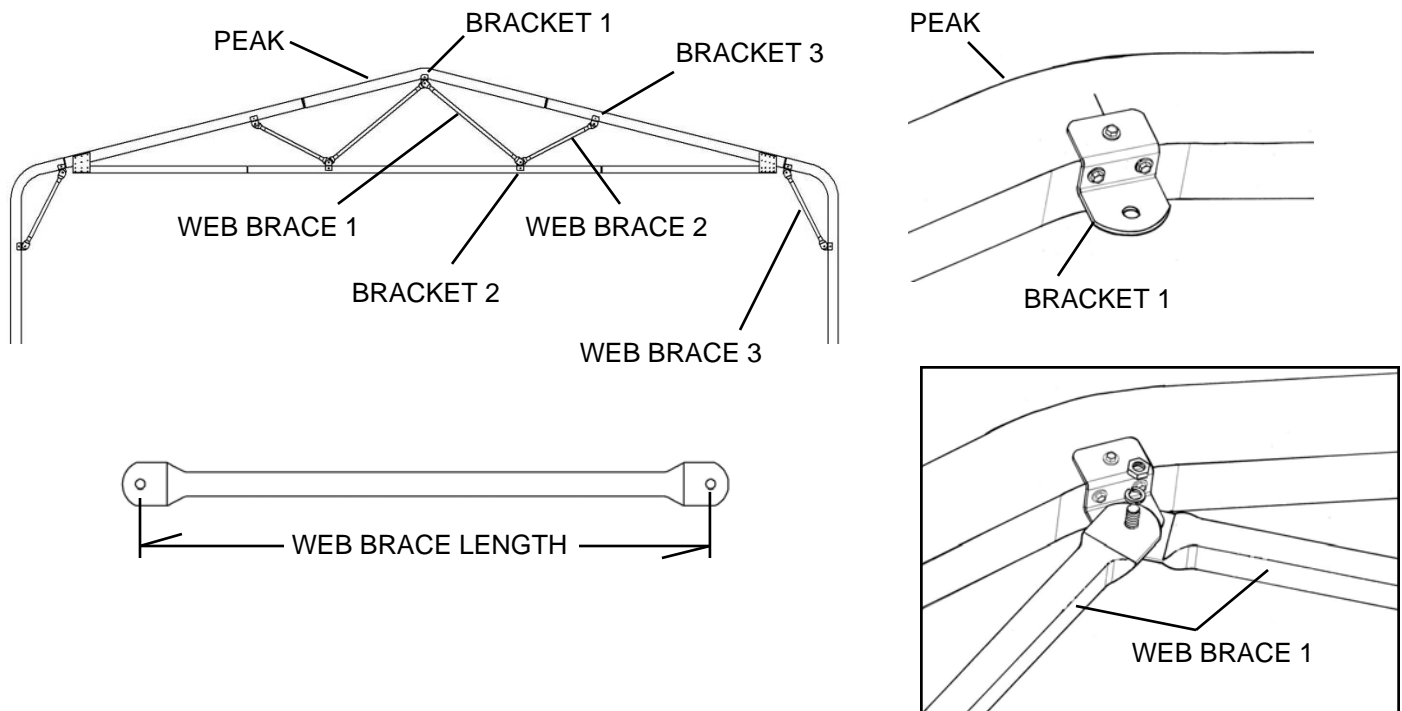

STEP 2: INSTALL TWO OF WEB BRACE 1: On 18' wide carports 30" long (part #76-3000), On 20' wide building 36" long (part # 76-3600), On 24' wide building 46" long (part #76-4600) and on 30' wide building 60" long (part # 76-6000). Place one of the brace ends on top of the Web Bracket tab and the other brace end on the bottom of the tab. Join the parts with a 3/8" x 1 1/4" hex bolt, lock washer and hex nut. Do not tighten at this time. It may be necessary to lift the frame to insert bolt.

STEP 3: INSTALL WEB BRACE 2: (On 18' & 20' carports 24") (On 24' carport 30") (On 30' wide carport 36") Loosely attach Web Bracket 2 to the other end of Web Brace 1. Place the Web Bracket on the Collar Tie (make sure the collar tie is straight and fasten the face of the bracket to the collar tie with a self-drilling screw. Remove the hex nut and attach one end of Web Brace 2 to the Web Bracket 2 assembly. (Like the first assembly, one brace end should be on one side of the web bracket tab and one on the other.) Now, loosely attach Web Bracket 3 to the other end of Web Brace 2 and fasten the bracket to the under side of the rafter. Repeat assembly for remaining Web Brace 2.

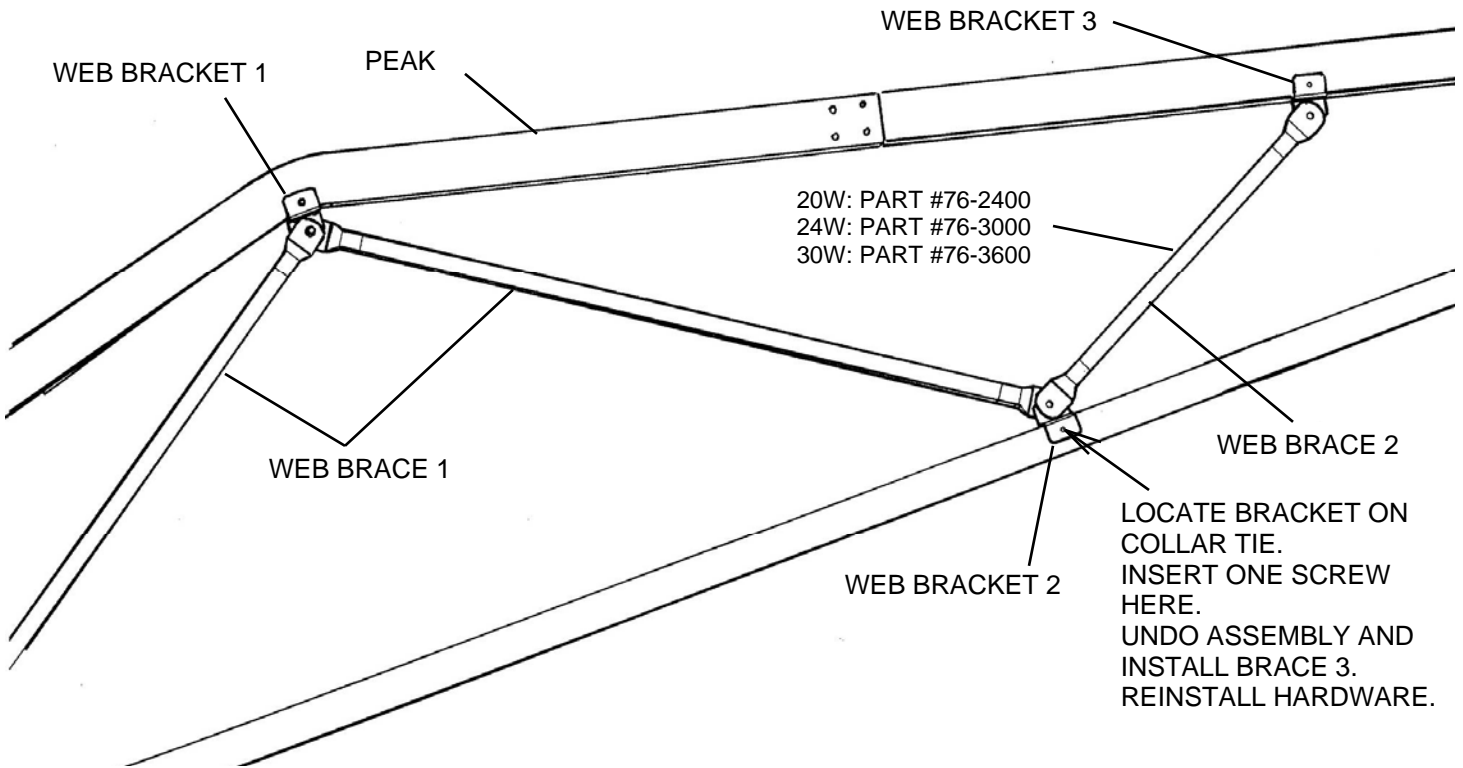

STEP 4: ASSEMBLING WEB BRACE 3: WEB BRACE 3 IS 24" LONG ON ALL CARPORTS (part #76-2400). Measure out 1" from the end of the Collar Tie and make a mark. This will be the location of the upper Web Bracket for Web Brace 3. Attach the upper Web Bracket with 3 self-drilling screws. Now, fasten Web Brace 3 to the upper Web Bracket with a hex bolt, lock washer and hex nut. (Do not tighten at this time.) Loosely attach a Web Bracket to the lower end of Web Brace 3 and place it against the side post. Re-check the carport dimension across the bottom of the frame 18', 20', 24', or 30' before attaching lower bracket to side post. Now, attach the face to the side post with a screw, remove the hex nut, let the bolt drop down and install the two screws in the side of the Web Bracket. Now, reinstall the bolt, lock washer and nut. Repeat assembly for remaining Web Brace 3 on the other side of the frame.

WHEN ALL BRACES ARE IN PLACE, TIGHTEN ALL HARDWARE. The nut size is 9/16". You may also need to hold the bolt head with pliers.

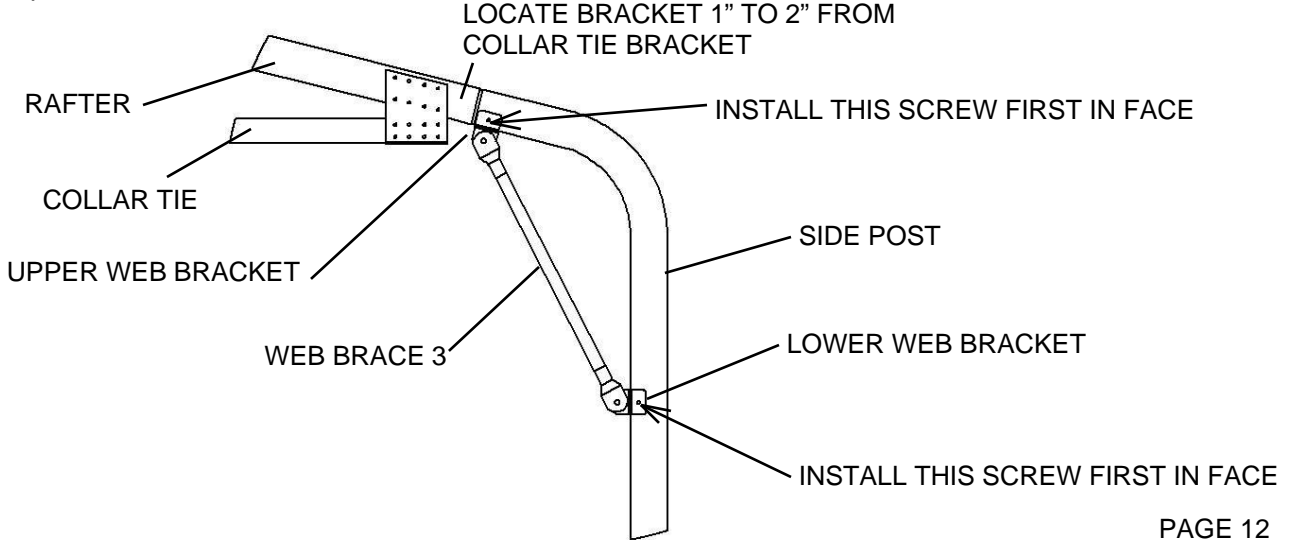

INSTALLING ROOF/WALL FRAMES SECTIONS TO BASE RAILS

NOTE: This assembly will require at least two people. 24' and 30' frames may require more. When raising a larger frame, the third person can walk the center of the frame up a ladder placed inside the carport.

Start at one end of the building and place a Roof/Wall frame assembly (**one with no truss brace**) on the first base rail vertical pins. Fasten joints with two screws each. Keep the screw heads away from the outside of the building where sheet metal may be installed. Check the bottom ends of the side posts or height extensions for dimples that might interfere with assembly to base rail pins. Dimples must be removed. (See page 2.)

Repeat this assembly until all Roof/Wall frame assemblies are installed. (Remember, no Truss Braces at the ends of the Carport.)

Place bottom of side posts on base rail pins at an angle. Raise frame section and drop it onto pins at the same time on both sides of the carport. Tap lightly on the side post with a hammer if parts do not drop into place.

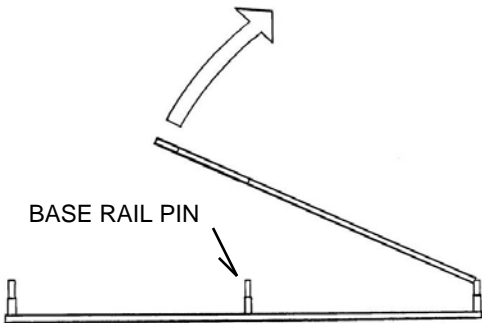

SQUARING UP YOUR FRAME

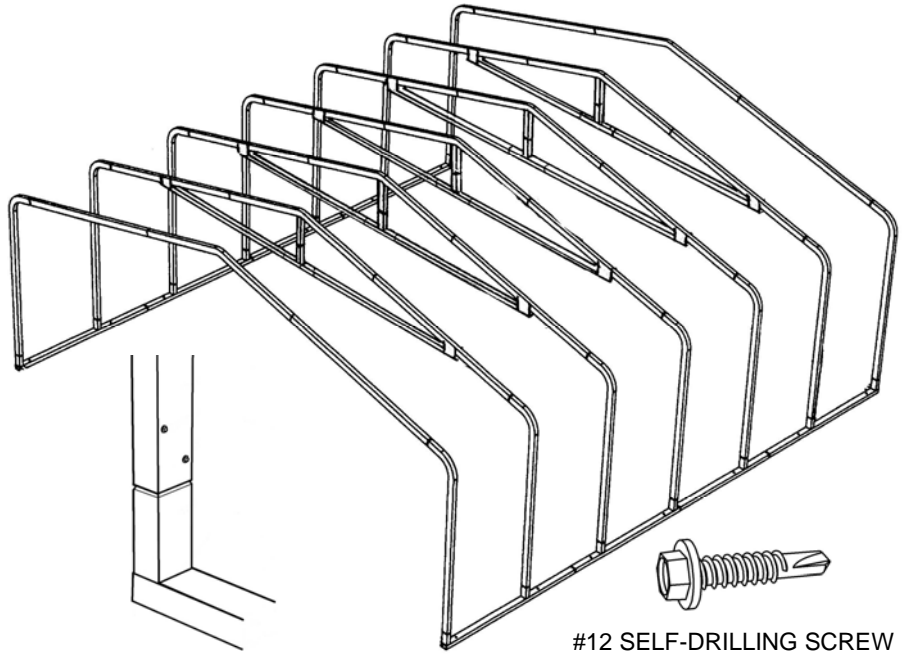

#12 SELF-DRILLING SCREW

Before you install sheet metal, you may want to check the Roof/Wall assemblies to make sure they are plumb and square and that the side post heights are equal.

To do this, first check the front and back Roof/Wall sections to make sure that they are plumb side to side. Check the outside of the side post. If adjustments must be made, you can drive a wooden or metal stake into the ground about 8' from the building and use a Motor Cycle strap or Ratchet strap to pull the side post into plumb. Place a clamp on the side post as shown and attach the strap above the clamp.

When the front and back sections are plumb (side to side), tie two strings from the front side post to the back side post at the bottom and top of the bend radius as shown. These strings will let you see which sections are high, low or out of plumb. If the side posts are high or low, remove the joint screws and raise the low posts and hammer down the higher posts as much as possible. Reinstall the screws in a new location. Check the height of the side posts on both sides of the building. The straps should remain in place until several runs of roof metal have been installed.

Note: This is not a critical step, but it may improve the appearance of your building. If side posts are out of plane with the other side posts more than 1/4", it may be visible.

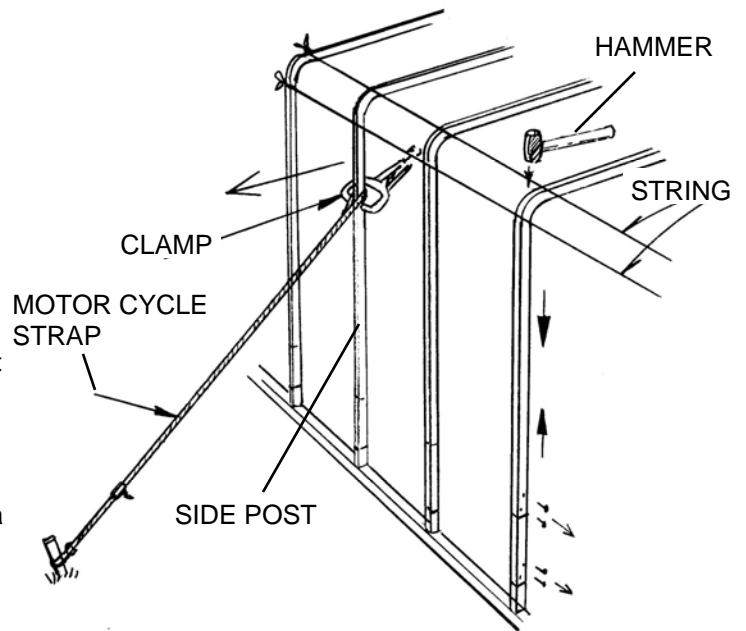

INSTALLING HORIZONTAL SHEET METAL ON THE CARPORT FRAME:

Different lengths, styles, and gauges of sheet metal panels can be installed on the Versatube frame. With the use of optional roof purlins, you can also install vertical sheet metal panels. For the purpose of these assembly instructions, we will be using sheet metal panels run horizontally. These instructions will cover the installation of roof and partial side panel coverage only.

Note: Adding additional side panels will effect the wind load applied to your structure. If you intend to add additional panels, you may require additional bracing or closer On Center spacing of the frame sections.

Carport frame sections will be on 4', 4 1/2', or 5' On Center spacing. Check to see which frame spacing you have. The length of the roof panels will be different for each frame spacing.

Panel lengths for:

4' On Center frame sections: 8'-7", 8'-2", 4'-2".

4 1/2' On Center frame sections: 10', 9'-2", 4'-8".

5' on center frame sections: 10'-6", 10'-2", 5'-2".

The panel lengths listed first above (8'-7", 10', and 10'-6") will always go at the ends of the roof and create an overhang (5" overhang on 4' or 5' On Center spacing— 11" overhang on 4 1/2' On Center spacing). The other lengths are designed to span ether 2 or 3 interior frame sections.

STEP 1: Installing Panel 1 (8'-7" for 4' O.C.) (10' for 4 1/2' O.C.) 10'-6" for 5' O.C.)

On the bottom of the panel, put a light pencil mark to indicate the overhang. (5" on 4' & 5' O.C. spacing) (11" on 4 1/2' O.C. spacing) This line will help you keep the overhang square with the end of the frame.

THE FIRST PANEL SHOULD BE INSTALLED ON THE LOW END OF THE CARPORT FOR PROPER DRAINAGE.

Before you assembled the Roof/Wall sections, you should have put a mark on one side of each peak as a guide for the under lap edge of the first run of panels down the peak of the carport. If you did not, refer to page 10 for the proper mark location for your building width.

Note: The illustration below is for 10', 12', 16', 18', 24' and 30' wide carports. See next page for 14' and 20' carports.

Place the first panel on the roof with the under lap edge of the panel lined up with the marks on the peaks and the end of the panel overhanging the end of the building 5" or 11" (see notes above). You may want to clamp the panel in place while installing the screws. With the panel lined up with all your marks, attach the panel to the first frame section with painted #12 x 1" self-drilling screws with rubber washers about 1" above the major ribs. **Do not install screws above the edge ribs at this time. You will be sliding the lower panels under the edges of the panels above.**

Before you install screws in the second frame section, check to see that it is square with the first section. Take a measurement between the frame sections at the base rail and transfer that dimension up to the peaks. Now, install screws in the second frame section. The other end of the panel should line up with the back of the third frame section. Do not install screws into the third frame section at this time.

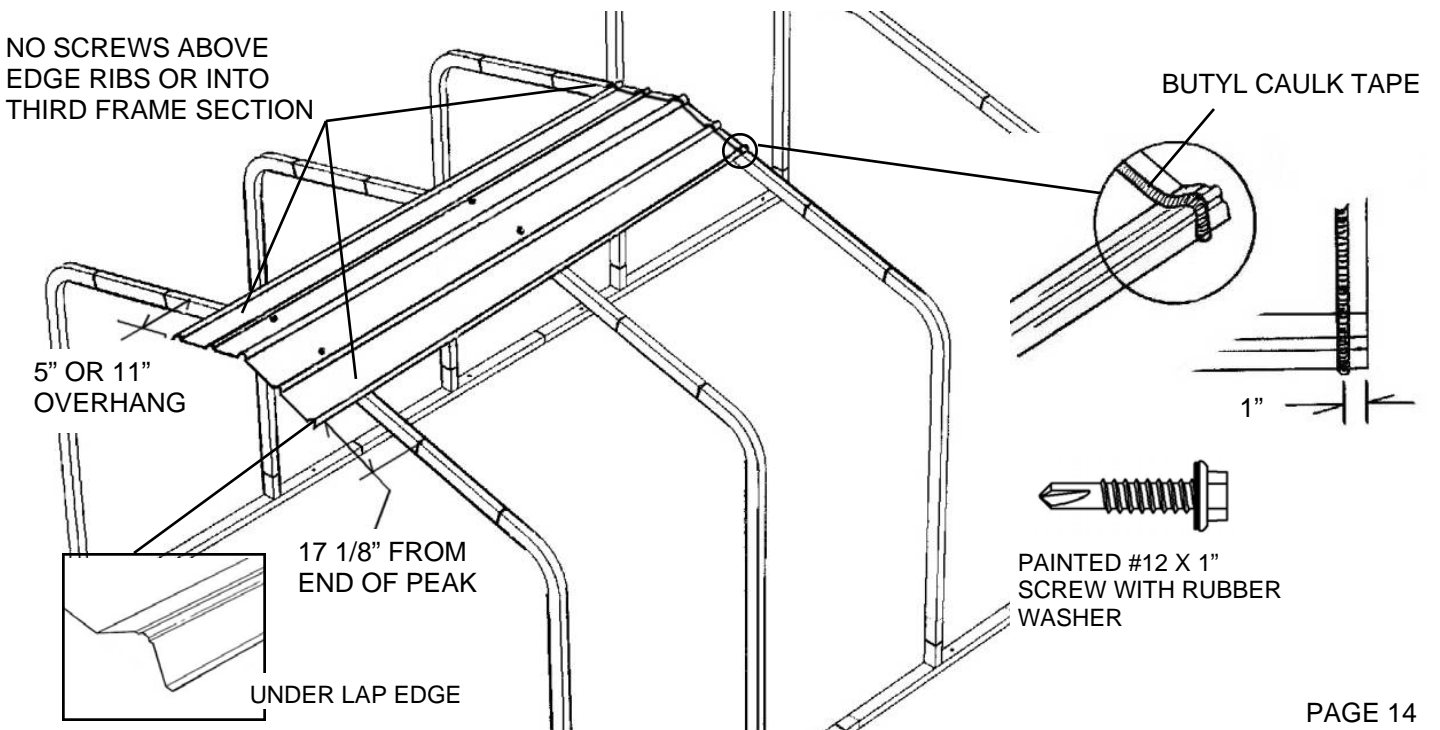

INSTALLING THE FIRST PANELS ON A 14' OR 20' WIDE CARPORT

When you install sheet metal panels on a 14' or 20' wide carport, the first course of panels down the peak will be positioned to one side of the roof and the first panels on the other side of the roof will overlap these panels 10" or to the second major rib. See illustration below.

If you have a 14' or 20' wide carport, you should have marked all of the peaks on the frame sections 3 5/8" from one end. This mark will be the guide for the under lap edge of the first course of roof panels. If you did not mark the peaks, mark them now. See page 10.

Install the first panel as shown below with the proper overhang (5" for 4' or 5' On Center frames and 11" for 4 1/2' On Center frames). Do not install screws above the lower edge ribs at this time. Do not install screws into the third frame section at this time.

Run a bead of butyl caulk tape at the back end of the panel 1" from the end. Let a little caulk extend slightly over each edge.

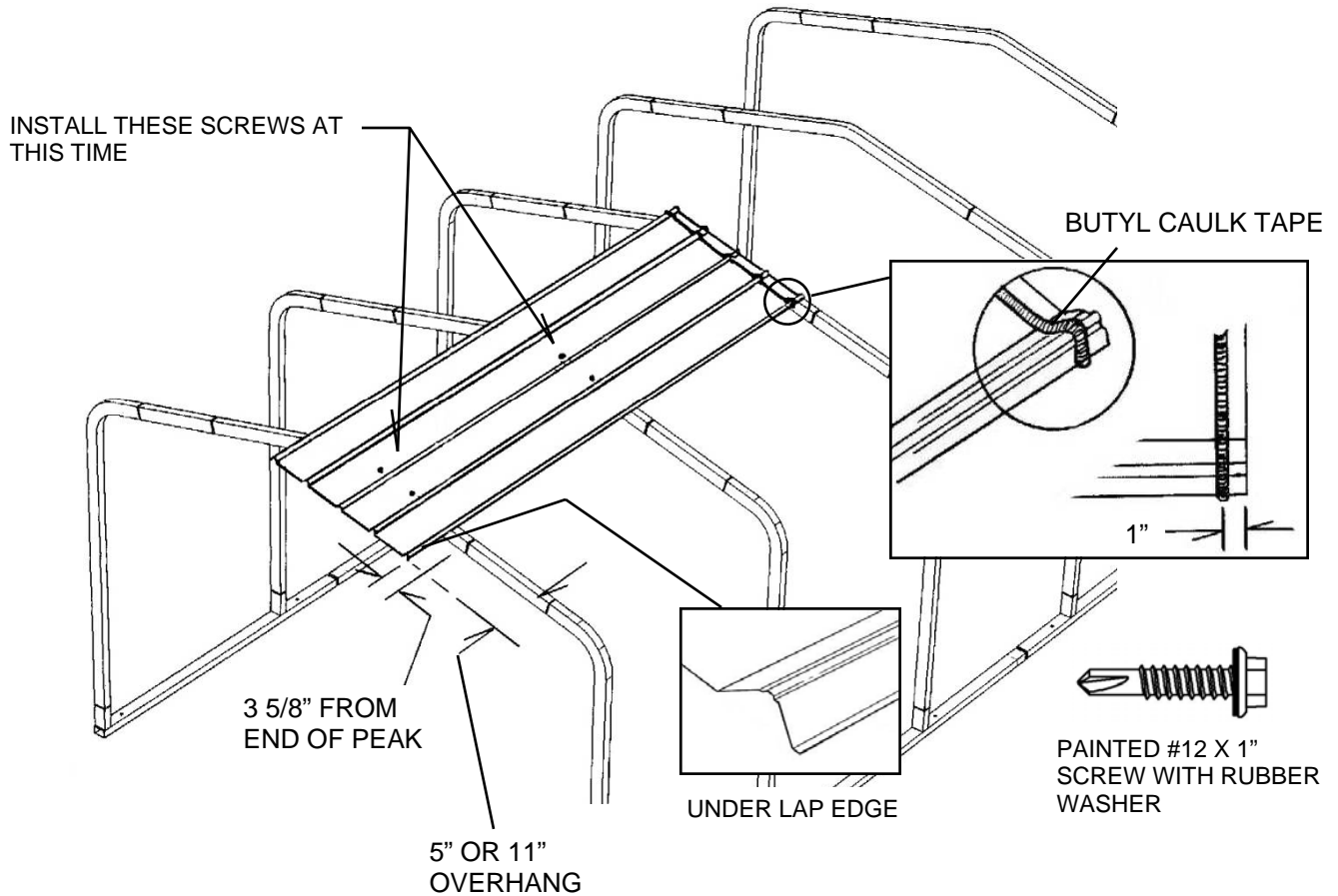

In order to seal panels properly and prevent leaking, each course of panels running from front to back on your carport must be completely sealed with butyl caulk tape or clear butyl caulk from a caulk gun. The ideal assembly would have full length roof panels. For purposes of shipping and handling, this is not possible. Several lengths of panels are provided and these lengths must be sealed together to extend the length of your carport.

You may have a carport that is longer or has more than two panels down the length of the carport. Each additional panel must be sealed to the previous panel, as you will seal panel two to panel one. See next page for Panel 2 installation.

INSTALLING PANEL TWO

If you have not removed the protective paper on the butyl tape that you applied to panel 1, do that at this time. Now, position panel two as shown below with a 2" overlap on panel one. Press the panels together well to create a good seal with the butyl caulk. The lower (under lap) edge of the panel should line up with the marks on the peaks. Before you install screws, make sure that the third frame section is the same distance from the second frame section at the base rail and at the peak. Attach the panel with screws on both sides of the major ribs at the lap joint and above the major ribs at other locations. Do not install screws above the lower edge rib or at the end of panels that continue on down the roof.

NOTE: If your carport frames are on 4' centers, the second panel will be 4'-2" long. If your carport frame is on 4 1/2' centers, the second panel will be 10' long. If your carport frame is on 5' centers, the second panel will be 10'-6" long.
REMEMBER: On longer carports, the end panels are the same length, center panels are shorter.

ADDITIONAL PANELS DOWN CARPORT LENGTH: Install additional panels down the length of the carport as needed in the same manner as you installed panel 2. See diagram below for panel guide.

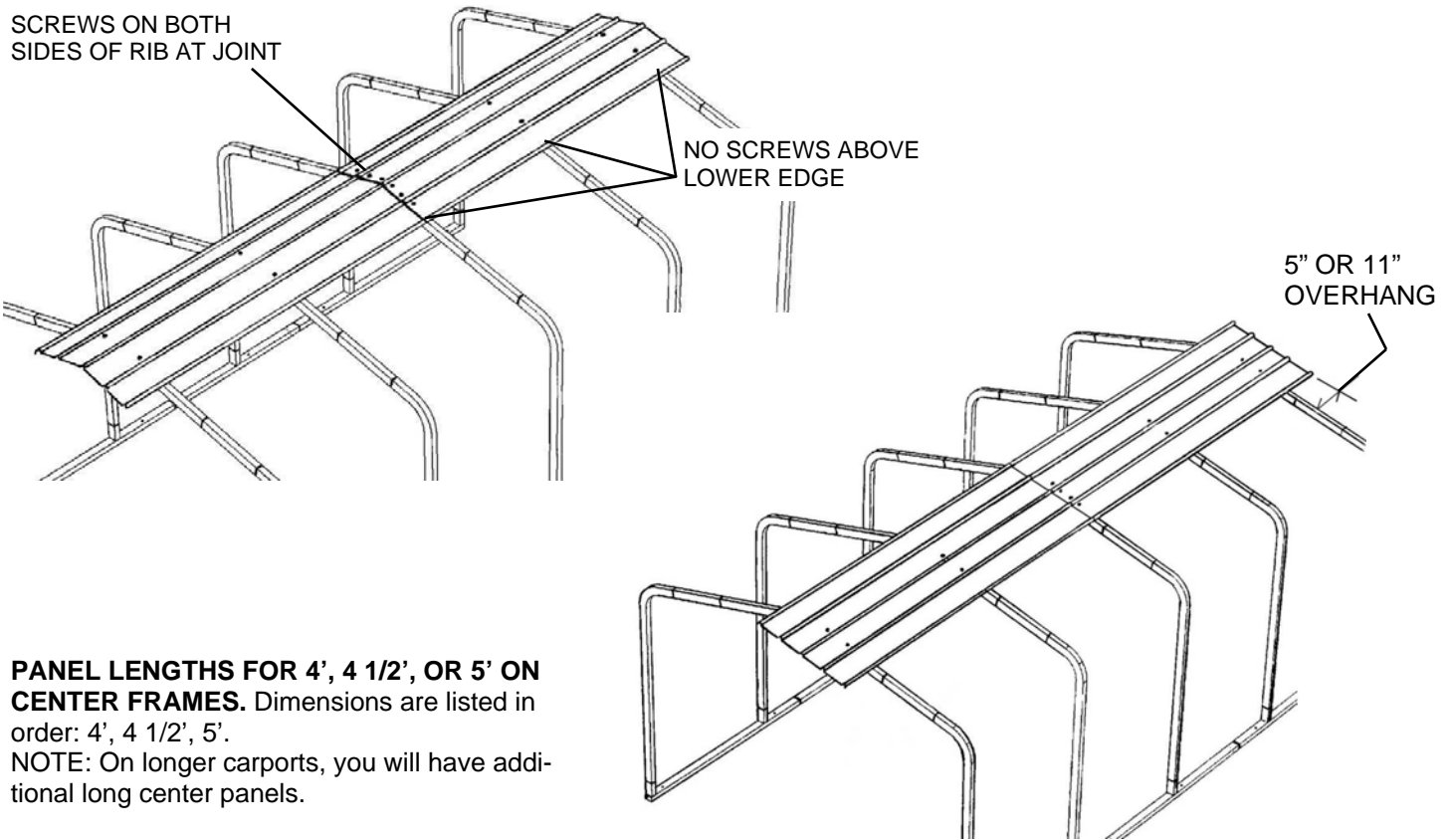

PANEL LENGTHS FOR 4', 4 1/2', OR 5' ON CENTER FRAMES. Dimensions are listed in order: 4', 4 1/2', 5'.

NOTE: On longer carports, you will have additional long center panels.

END PANEL 8'-7", 10' OR 10'-6"	SHORT PANEL 4'-2", 4'-8" OR 5'-2"	END PANEL 8'-7", 10' OR 10'-6"
--------------------------------	---	--------------------------------

END PANEL 8'-7", 10' OR 10'-6"	LONG CENTER PANEL 8'-2", 9'-2" OR 10'-2"	END PANEL 8'-7", 10' OR 10'-6"
--------------------------------	---	--------------------------------

END PANEL 8'-7", 10' OR 10'-6"	SHORT PANEL 4'-2", 4'-8" OR 5'-2"	LONG CENTER PANEL 8'-2", 9'-2" OR 10'-2"	END PANEL 8'-7", 10' OR 10'-6"
--------------------------------	---	---	--------------------------------

Install all panels down the peak of the carport before moving on to the second lower course of panels.

INSTALLING THE SECOND LOWER COURSE OF PANELS ON CARPORTS 10', 12', 16', 18', 24' AND 30' WIDE

The second course of panels will be installed starting at the **opposite** end of the carport. Slide the under lap edge of the first panel of the second course under the lower edge of the last panel in the first course. Note: On one side of the roof, you will be inserting a under lap edge under an under lap edge. This is fine and it only occurs once. In the rest of the installation, the under lap rib will go under an overlap rib. Install the screws at the end of the carport to hold the panel in place. (No screws above the lower edge at this time.)

Select the next panel to be installed and run a bead of butyl caulk tape on one end 1" from the end. The panel should be positioned with the under lap edge on the upper side of the panel. Remove the protective paper from the butyl caulk. Now, lift the end of the panel you just installed and the edge of the first course of panels above and insert the next panel 2" under the previous panel. Check your dimensions and press the panel overlap tightly together. Install screws in the overlap joint and all screws in the previous panel and the panels above that will not have to be lifted to insert additional panels. Note: To reach all of the screw locations, you will have to get up high on your ladder and lean on the roof with your hand or knee. When you do this, press only on the flat sections between ribs and make sure that you press only over a frame section. Continue this installation method until the roof is sheeted on one side. The last panel on the side will be bent down around the frame and become a short side panel. Start all panels courses from the end of the carport that you started the second course of panels.

IF YOU HAVE A 14' OR 20' WIDE CARPORT

Start the second course of panels at the end of the carport where you started the first course of panels. Lap the under lap edge of the first panel in the second course over the peak of the roof and onto the second major rib of the last panel in the first course. (See lap detail below.) Install several screws above the edge rib from the side of the carport that you installed the first course of roof metal (no screws into the end of the panel at the third frame section). Now, press the panel down at the peak and on the other side of the roof and install screws in locations indicated below.

Run a bead of butyl caulk tape on the end of the panel 1" in from the end. Extend the ends of the tape a little over the edges of the panel. **NOTE:** The panels that overlap over the peak are the only panels that overlap by (2) ribs. All other laps only overlap by (1) rib.

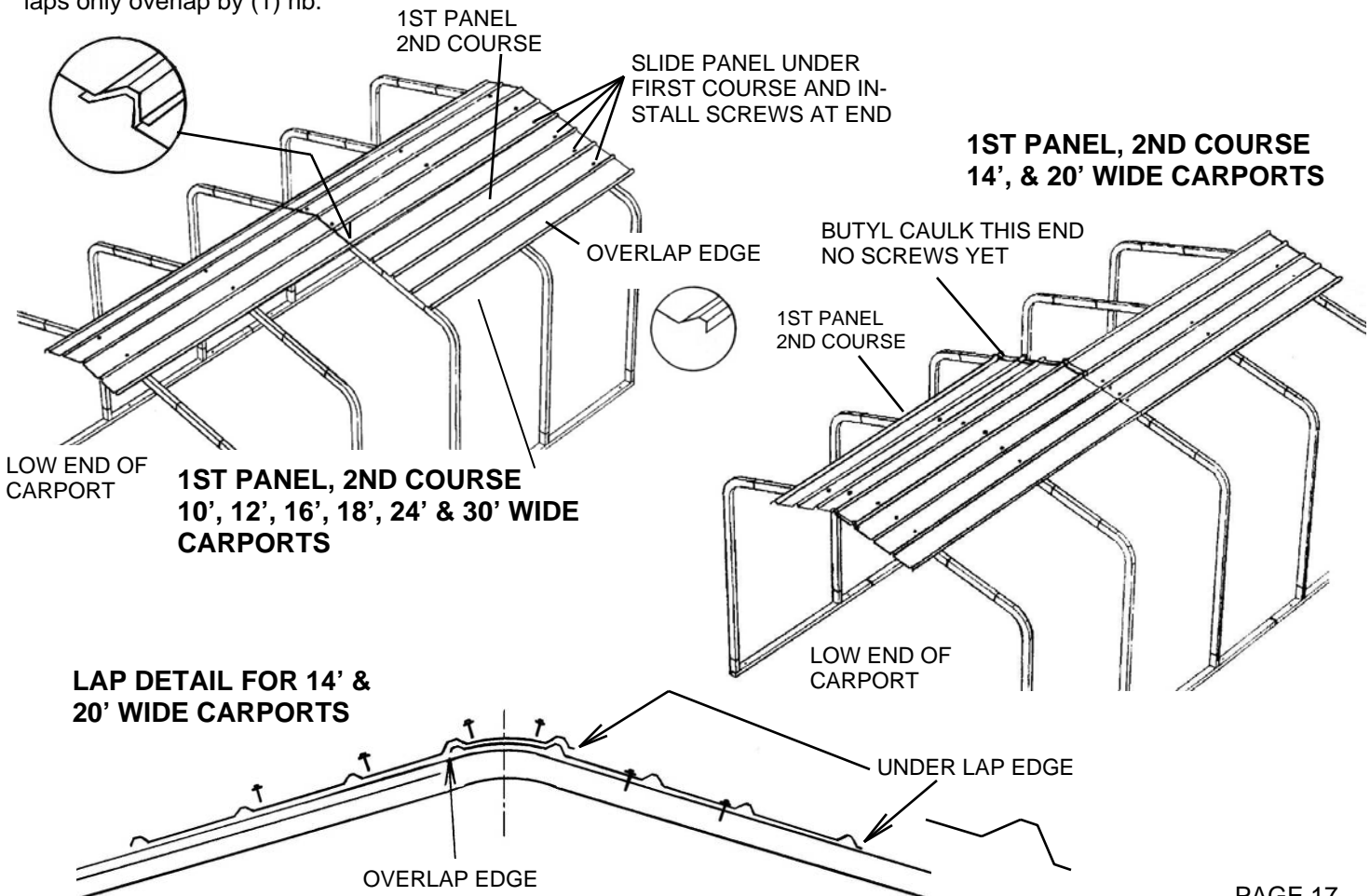

INSTALLING THE 2ND PANEL, 2ND COURSE AND ADDITIONAL PANELS 2ND COURSE

10', 12', 16', 18', 24', AND 30' WIDE CARPORTS:

See the chart on the bottom of page 17 for panel sizes required for the on center frame spacing of your carport. The additional panel/panels in the second course must be positioned with the under lap edge to the upper side of the panel. The upper under lap edge of the panel will lap under the panel above and the end of the panel will lap under the panel you just installed. Run a bead of butyl caulk on the end to be lapped under the previous panel 1" from the end and remove the protective paper. Now, lift the panels above and the previous panel in the course you are installing and slide the upper edge of the panel under the panel above and the end 2" under the previous panel. Press the panels together well at the caulked end to get a good seal. For longer carports, continue installing panels in the same manner to the end of the carport. Both ends of the carport should have the same overhang.

Additional Courses of Sheet metal: Start all additional courses of metal on the carport at the same end as you started the second course (the high end of the carport). Install them in the same manner. Place under lap edges under overlap edges.

14' AND 20' WIDE CARPORTS:

See the chart on the bottom of page 17 for panel sizes required for the on center frame spacing of your carport. The additional panel/panels in the second course must be positioned like the first panel in the second course with the Under lap edge over the peak of the carport and onto the second rib of the first course (NOTE: Only overlap by 2 ribs over the peak). Remove the protective paper on the butyl caulk and place the end of the second panel 2" over the end of the previous panel. With the ribs lined up and the panel pressed down to the frame, install the screws as shown below. Install the screws first on the side of the roof that you installed the first course of panels. For longer carports, continue installing panels in the same manner to the end of the carport. Both ends of the carport should have the same overhang.

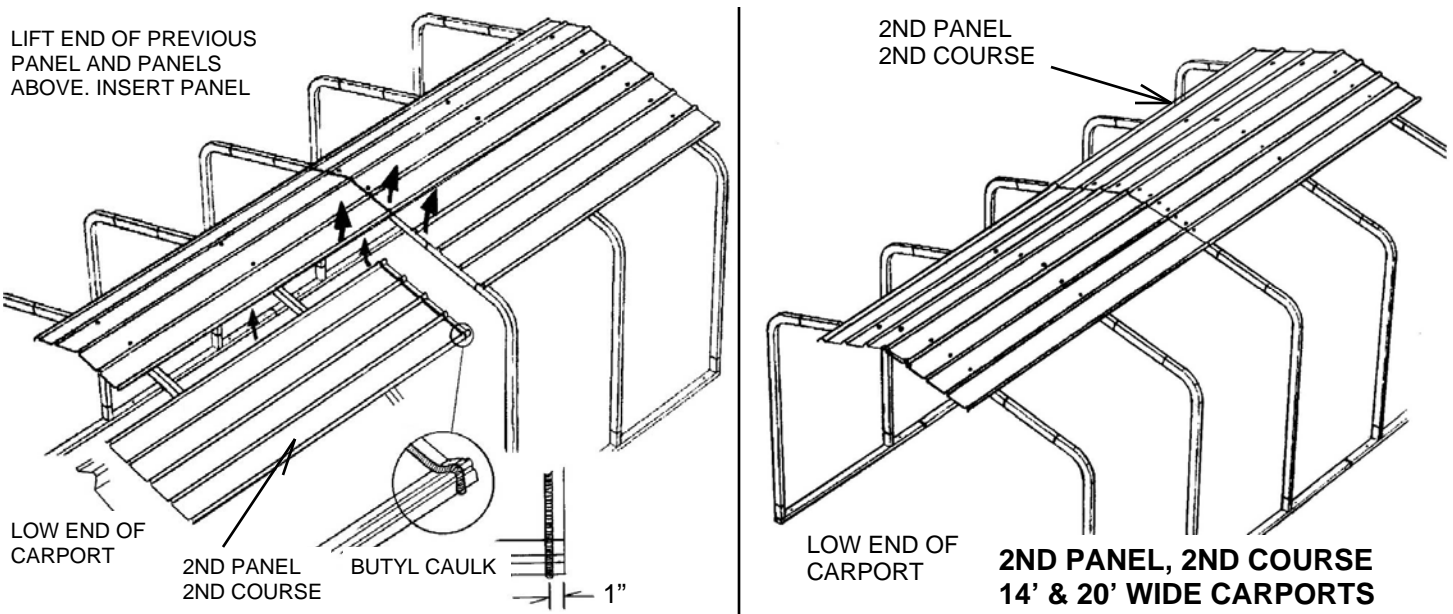

2ND PANEL, 2ND COURSE 10', 12', 16', 18', 24' & 30' WIDE CARPORTS

INSTALLING ADDITIONAL PANELS:

All additional panels on 10', 12', 16', 18', 24' and 30' wide carports should start on the high end of the carport (same as second course) and be installed in the same manner.

All additional panels on 14' and 20' wide carports should start at the high side of the carport (the opposite end that you started the 1st and 2nd course) and be installed like the 3rd course shown at right.

NUMBER OF COURSES: 10' & 12' wide (5), 14' wide (6), 16' & 18' wide (7), 20' wide (8), 24' wide (9), and 30' wide (11).

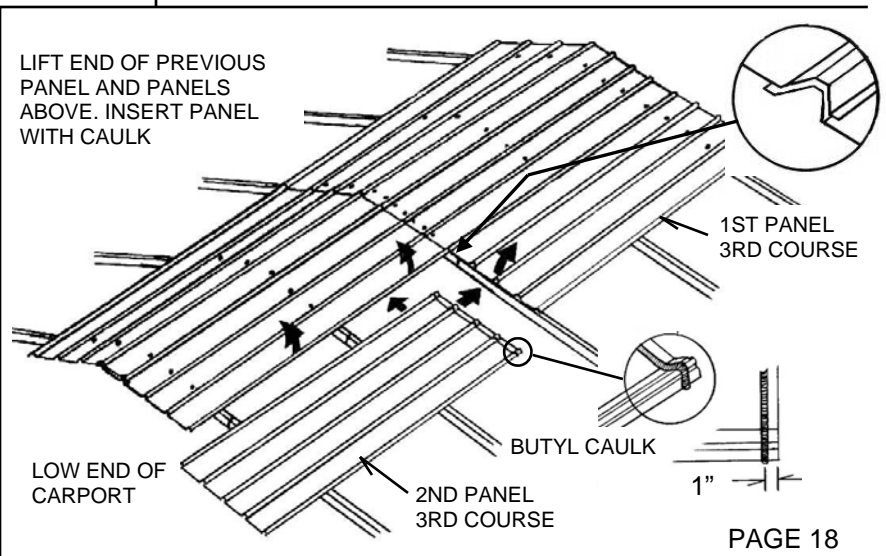

INSTALLING VINYL EDGE TRIM:

Install vinyl edge trim on front, back and side edges of sheet metal panels. Start at one corner and push the trim securely over the sheet metal edge. Install the trim on the gable ends first starting at one corner, up along the gable and down to the other corner. Install vinyl edge trim on both side edges of the carport. Clip the trim flush with the edge of the trim on the gable ends. It may help to use a small hammer to fit trim over major ribs. Use your tin snips to cut the trim.

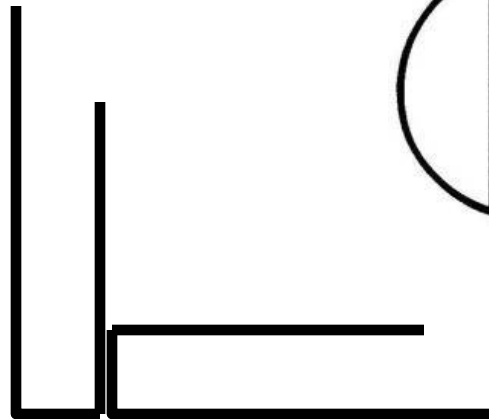
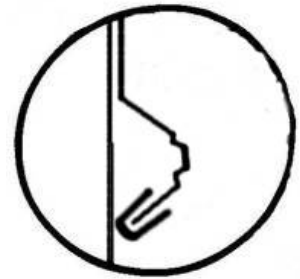
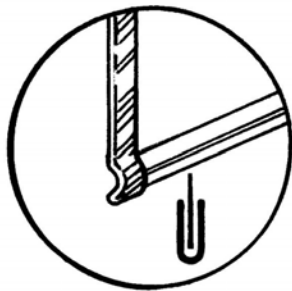
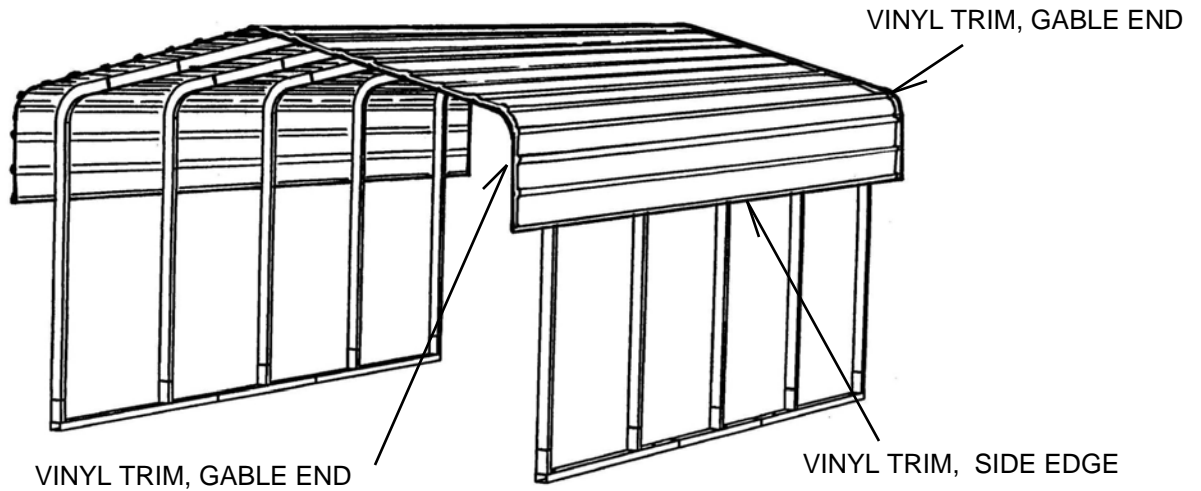

BUTT SIDE EDGE TRIM UP TO GABLE END TRIM

NOTE: The carport could also be trimmed out with metal trim. Metal trim is not provided. The gable ends can be trimmed with Angle Trim and the side edges can be trimmed with J-Trim.

IMPORTANT:

All of the metal shavings created by the installation of self-drilling screws must be washed or swept off of the carport roof. These raw metal shavings will rust and stain the roof panels.